

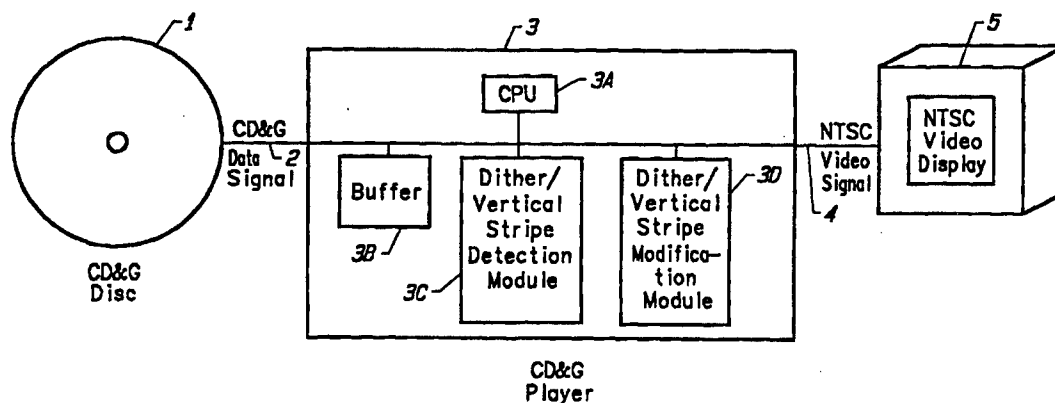

INTERNATIONAL APPLICATION PUBLISHED UNDER THE PATENT COOPERATION TREATY (PCT)

(51) International Patent Classification ⁶ : G06K 9/00	A1	(11) International Publication Number: WO 96/37860 (43) International Publication Date: 28 November 1996 (28.11.96)
<p>(21) International Application Number: PCT/US96/06430</p> <p>(22) International Filing Date: 8 May 1996 (08.05.96)</p> <p>(30) Priority Data: 08/447,003 22 May 1995 (22.05.95) US</p> <p>(71) Applicant: THE 3DO COMPANY [US/US]; 600 Galveston Drive, Redwood City, CA 94063 (US).</p> <p>(72) Inventors: HAYES, Steven, E.; 141 Via Trinita, Aptos, CA 95003 (US). MacDONELL, Kevin, S.; 5374 Roxanne Drive, San Jose, CA 95124-5640 (US). WASSERMAN, Steven, C.; Apartment 22F, 60 Wadsworth Street, Cambridge, MA 02142 (US).</p> <p>(74) Agents: WOLFELD, Warren, S. et al.; Fliesler, Dubb, Meyer and Lovejoy, Suite 400, Four Embarcadero Center, San Francisco, CA 94111-4156 (US).</p>	<p>(81) Designated States: AL, AM, AT, AU, AZ, BB, BG, BR, BY, CA, CH, CN, CZ, DE, DK, EE, ES, FI, GB, GE, HU, IS, JP, KE, KG, KP, KR, KZ, LK, LR, LS, LT, LU, LV, MD, MG, MK, MN, MW, MX, NO, NZ, PL, PT, RO, RU, SD, SE, SG, SI, SK, TJ, TM, TR, TT, UA, UG, UZ, VN, ARIPO patent (KE, LS, MW, SD, SZ, UG), Eurasian patent (AM, AZ, BY, KG, KZ, MD, RU, TJ, TM), European patent (AT, BE, CH, DE, DK, ES, FI, FR, GB, GR, IE, IT, LU, MC, NL, PT, SE), OAPI patent (BF, BJ, CF, CG, CI, CM, GA, GN, ML, MR, NE, SN, TD, TG).</p> <p>Published <i>With international search report.</i></p>	

(54) Title: METHOD AND APPARATUS FOR DETECTING AND MODIFYING DITHER/VERTICAL STRIPE PATTERNS IN AN IMAGE



(57) Abstract

A method and apparatus that detects and modifies "dither" and/or "vertical stripe" patterns encoded on a compact audio and graphics (CD+G) disc (1). The method and apparatus modifies the alternating color pixel patterns in order to eliminate luma/chroma crosstalk in National Television System Committee (NTSC) display systems. CD+G data signals (2) representing individual tiles of an image on a television display are examined for "dither" and/or "vertical stripe" patterns (3). The tiles represent a matrix of color coded pixels. Once a "dither" and/or "vertical stripe" pattern is detected in a tile or a portion thereof, the pixel color values representing the alternating color coded pixels are averaged. The averaged value is then substituted in the "dither" or "vertical stripe" pattern, thereby eliminating luma/chroma crosstalk.

FOR THE PURPOSES OF INFORMATION ONLY

Codes used to identify States party to the PCT on the front pages of pamphlets publishing international applications under the PCT.

AM	Armenia	GB	United Kingdom	MW	Malawi
AT	Austria	GE	Georgia	MX	Mexico
AU	Australia	GN	Guinea	NE	Niger
BB	Barbados	GR	Greece	NL	Netherlands
BE	Belgium	HU	Hungary	NO	Norway
BF	Burkina Faso	IE	Ireland	NZ	New Zealand
BG	Bulgaria	IT	Italy	PL	Poland
BJ	Benin	JP	Japan	PT	Portugal
BR	Brazil	KE	Kenya	RO	Romania
BY	Belarus	KG	Kyrgystan	RU	Russian Federation
CA	Canada	KP	Democratic People's Republic of Korea	SD	Sudan
CF	Central African Republic	KR	Republic of Korea	SE	Sweden
CG	Congo	KZ	Kazakhstan	SG	Singapore
CH	Switzerland	LI	Liechtenstein	SI	Slovenia
CI	Côte d'Ivoire	LK	Sri Lanka	SK	Slovakia
CM	Cameroon	LR	Liberia	SN	Senegal
CN	China	LT	Lithuania	SZ	Swaziland
CS	Czechoslovakia	LU	Luxembourg	TD	Chad
CZ	Czech Republic	LV	Latvia	TG	Togo
DE	Germany	MC	Monaco	TJ	Tajikistan
DK	Denmark	MD	Republic of Moldova	TT	Trinidad and Tobago
EE	Estonia	MG	Madagascar	UA	Ukraine
ES	Spain	ML	Mali	UG	Uganda
FI	Finland	MN	Mongolia	US	United States of America
FR	France	MR	Mauritania	UZ	Uzbekistan
GA	Gabon			VN	Viet Nam

METHOD AND APPARATUS FOR DETECTING AND
MODIFYING DITHER/VERTICAL STRIPE PATTERNS IN AN IMAGE

I. BACKGROUND OF THE INVENTION

5 A. Field of the Invention

This invention relates to an apparatus and method for generating an image. More specifically, this invention relates to detecting and modifying dither and/or vertical stripe pixel patterns in order to enhance an image on a video display.

10

B. Description of the Related Art

In many image display system applications, a limited amount of colors or a relatively small color palette is available for each pixel on an image. In order to increase the number of colors in which a viewer
15 may perceive in an image, sections or tiles of the image may be coded with pixel patterns representing colors which are not found in the color palette. These patterns are typically called "dither".

For example, by coding dither patterns in a video signal, a video display system which is limited by a relatively small color palette can
20 appear to have a far greater number of colors available and thus, images seen on the display may be presented which appear to have a far greater color spectrum or variety of colors.

A compact audio disc system is an example of such a video display system. Compact audio discs have had the capability to
25 display graphic data since the mid-1980s given a suitable player and a display. These compact audio discs are commonly called CD+G discs. The model used in CD+G disc systems involves dividing up or partitioning a television display into a matrix of tiles. The television display may be a National Television System Committee (NTSC)
30 television. Each tile is further partitioned into a matrix of pixels. The

CD+G disc data is encoded to provide operations which effect a specified tile or all tiles at once. The industry CD+G specification allows for only a 16-color palette, except with television graphics. This limited color palette has prompted some CD+G designers to use dithering to simulate additional colors. For example, pink may not be included in the color palette and may be simulated in a portion of a tile, or in a number of tiles, by a dither pattern which alternates between a red (a color included in the color palette) illuminated pixel and a white (a color also included in the color palette) illuminated pixel to simulate pink.

The use of dither or vertical stripe patterns can cause a phenomena known as "luma/chroma crosstalk" in a video display system. Dither and/or vertical stripe patterns have high spectral energy in the horizontal direction of an NTSC television display. In the situation where a "square" pixel aspect ratio is used in NTSC television signals, this corresponds to $12.272727/4 = 3.07\text{MHz}$. The spectral energy at this frequency causes luma/chroma crosstalk in composite television signals because it is close to the color carrier frequency of 3.579545 MHz. The dither signal will be incorrectly interpreted by an NTSC television as color information. Because the phase of the color information changes on each displayed picture (and the dither pattern remains constant), the image flashes or flickers wildly.

C. Patents and Literature

By way of example, the following United States patents and literature, all of which are incorporated by reference herein, discuss various aspects of image processing and/or dither patterns. The patents and literature include:

1. Patents

	<u>U.S. Patent No.:</u>	<u>Title:</u>	<u>Inventor(s):</u>
	4,652,905	INSTANTANEOUS NEUTRAL COLORS IN DITHER- QUANTIZED COLOR TELEVISION	Bernard Lippel
5	4,924,301	APPARATUS AND METHODS FOR DIGITAL HALFTONING	Craig L. Surbrook
	5,333,260	IMAGING SYSTEM WITH MULTILEVEL DITHERING USING BIT SHIFTER	Robert A. Ulichney
	4,758,893	CINEMATIC DITHERING FOR TELEVISION SYSTEMS	Bernard Lippel
	4,682,216	COLOR IMAGE PICTURE FORMING PROCESS AND APPARATUS WHICH IMPROVES THE QUALITY OF THE BLACK PORTIONS OF THE PICTURE	Takashi Sasaki Nobuaki Sakurada Hideaki Kawamura Jiro Moriyama
	4,647,968	ANALOG-TO-DIGITAL CONVERSION SYSTEM AS FOR A NARROW BANDWIDTH SIGNAL PROCESSOR	Donald H. Willis
10	4,682,360	VIDEO TRANSMISSION SYSTEM	Jeffrey E. Frederiksen
	4,605,961	VIDEO TRANSMISSION SYSTEM USING TIME-WARP SCRAMBLING	Jeffrey E. Frederiksen
	4,670,780	METHOD OF MATCHING HARDCOPY COLORS TO VIDEO DISPLAY COLORS IN WHICH UNREACHABLE VIDEO DISPLAY COLORS ARE CONVERTED INTO REACHABLE HARDCOPY COLORS IN A MIXTURE- SINGLE-WHITE (MSW) COLOR SPACE	Paul A. McManus Gregory L. Hoffman

	4,970,586	HALF-TONE IMAGE REPRODUCING METHOD OF IMPROVING GRADATION WITHOUT LOSS OF RESOLUTION	Fumihiro Sunda Toshiyuki Yamaguchi
	4,930,018	METHOD AND SYSTEM FOR ENHANCING THE QUALITY OF BOTH COLOR AND BLACK AND WHITE IMAGES PRODUCED BY INK JET PRINTERS	C.S. Chan James G. Bearss Terry M. Nelson
	4,965,668	ADAPTIVE ROUNDER FOR VIDEO SIGNALS	John Abt James A. Delwiche
	5,087,809	SPECTRALLY SELECTIVE DITHERING AND COLOR FILTER MASK FOR INCREASED IMAGE SENSOR BLUE SENSITIVITY	Todd A. Jackson
5	5,333,262	IMAGING SYSTEM WITH MULTILEVEL DITHERING USING TWO MEMORIES	Robert A. Ulichney
	5,053,887	TECHNIQUE FOR PRODUCING A FINE GRAINED DITHERED HALFTONE IMAGE HAVING AN INCREASED NUMBER OF GRAY LEVELS	Gerhard R. Thompson
	4,528,584	BILEVEL CODING OF COLOR VIDEO SIGNALS	Mohammed S. Sabri

II. SUMMARY OF THE INVENTION

10 A method and apparatus for detecting and modifying dither and/or vertical stripe pixel patterns in an image is provided.

The method for detecting a dither pattern in an image comprises the steps of examining a first center two pixel values in a first row of a tile. The tile comprises a 6 pixel row by 12 pixel column matrix.
15 The first center two pixel values are then compared to the adjacent pixel values in order to determine whether a dither pattern is present in the image.

According to another aspect of the invention, the first center two pixel values include a first color value and a second color value and the adjacent pixel values include the first color value and the second color value.

5 According to another aspect of the present invention, the pixel color values are retrieved from a CD+G disc and are used to generate an NTSC television signal. The pixel color values from the CD+G disc are also selected from a relatively small group of colors.

 According to yet another aspect of the present invention, a
10 method for detecting a vertical stripe pattern in an image to be displayed is provided. The method comprises the steps of examining the first center two pixel color values in the first row of a tile and examining a second center two pixel color values in a second row of the tile of the image to be displayed. The first center two pixel color
15 values and the second two pixel color values are then compared in order to determine whether the vertical stripe pattern is present in the image. The first center two pixel color values include a first color value and a second color value, respectively, and the second center two pixel color values include the first color value and the second color
20 value, respectively.

 According to another aspect of the invention, a method for eliminating luma/chroma crosstalk in an NTSC display is provided. A tile of an image to be displayed on the NTSC display is stored in a
25 memory location. A first center two pixel color values in a first row of the tile of the image, including a first color value and a second color value, is examined along with adjacent pixel color values. The first center two pixel color values and the adjacent pixel color values are compared in order to determine whether a dither/vertical stripe pattern is in the tile. The first color value and the second color value are

averaged to obtain an average color value. Finally, the first color value and the second color value stored in the memory location are substituted with the average color value.

According to another aspect of the invention, an apparatus for
5 detecting a dither/vertical pixel pattern in an image to be displayed is provided. A source of color pixel values for an image is coupled to a means for examining 1) a first center two pixel color values in a first row of a section of an image and 2) an adjacent pixel color values in a section of the image. Means for comparing the first center two pixel
10 color values to the adjacent pixel values is used in order to determine whether a dither/vertical stripe pattern is in the image.

According to still another aspect of the invention, the section of the image is a tile comprising a 6 pixel row by an 12 pixel column matrix. The pixel color value source is from a CD+G disc and the
15 pixel color values are used in an NTSC color carrier frequency signal at about 3.5Mhz. The color values are selected from an approximately 16 color palette.

According to another aspect of the invention, the means for examining and means for comparing includes a software routine.

20 According to yet another aspect of the present invention, an apparatus for eliminating "luma/chroma cross-talk" in an image to be displayed on an NTSC television screen is provided. The apparatus comprises a memory storing pixel color values of a section of an image. The memory is coupled to a means for examining 1) a first
25 center two pixel color values, which include a first color value and a second color value, respectively, in a first row of the section of the image and 2) adjacent pixel color values in a section of the image. Means for comparing the first center two pixel color values to the adjacent pixel color values in order to determine whether a

dither/vertical stripe pattern in the image is also coupled to the memory. Finally, means for modifying the first color value and the second color value stored in the memory with an average color value of the first color value and a second color value is also coupled to the
5 memory.

Other aspects and advantages of the present invention can be seen upon review of the figures, the detailed description, and the claims which follow.

10 III. BRIEF DESCRIPTION OF THE DRAWINGS

Figure 1 is a block diagram of an apparatus according to the present invention.

Figure 2 illustrates a partitioning of an NTSC video display according to the present invention.

15 Figure 3 illustrates a typical dither pattern.

Figure 4 illustrates a typical vertical stripe pattern.

Figure 5 illustrates a dither detection logic flow chart according to the present invention.

20 IV. DETAILED DESCRIPTION OF THE INVENTION

Figure 1 illustrates a Compact Audio and Graphics (CD+G) disc player embodiment according to the present invention. CD+G disc 1 generates a CD+G data signal on data path 2 to CD+G player 3. CD+G data is stored in buffer 3b in CD+G player 3.

25 In the preferred embodiment, CD+G player 3 includes a central processing unit (CPU) 3a. In an alternate embodiment, CPU 3a may not be physically located in CD+G player 3, but alternatively in NTSC video display 5 or at a remote location along a data path to the NTSC display. For example, CPU 3a could be located at a cable or satellite

transmission site. Among other control functions, CPU 3a controls the CD+G data signal from CD+G disc 1 as well as the generation of NTSC video signal on data path 4 to NTSC video display 5.

Furthermore, it should be understood that other embodiments may not include a buffer 3b. The present invention may process a CD+G data signal in real-time from a television cable or data link, such as a satellite signal. Likewise, it should be understood that other embodiments may include a printer. Thus, pixel is defined as color or luminance information in an image which may be represented electronically or physically.

Graphical images represented by CD+G data signals are stored in buffer 3b and are eventually displayed on NTSC video display 5 by an NTSC video signal. The CD+G data signals include individual pixel color information for the image to be displayed on NTSC video display 5. The logical partitioning of pixel color information which forms an image on NTSC video display 5 is illustrated in Figure 2.

CD+G player 3 also includes dither/vertical stripe detection module 3c. Detection module 3c, along with CPU 3a, determines whether a dither and/or vertical stripe is present in the CD+G data stored in buffer 3b. The detection of a dither and/or vertical stripe in buffer 3b is discussed in greater detail below.

Likewise, CD+G player 3 includes a dither/vertical stripe modification module 3d which is used to modify dither and/or vertical stripes detected by detection module 3c in buffer 3b. The dither/vertical stripe modification module then modifies the CD+G data in buffer 3b. The modified data is then used in an NTSC video signal eliminating the conditions causing the luma/chroma crosstalk. The modification module 3d is discussed in greater detail below.

Figure 2 illustrates how CD+G data is partitioned or mapped on NTSC video display 5. NTSC video display 5 is partitioned into a 50 by 18 matrix of tiles. Individual tiles are represented by tiles 5a and 5b. Each tile includes a 6 horizontal pixel by an 12 vertical pixel matrix. The CD+G data stored in buffer 3b may not be physically located or arranged in the same manner as is displayed in Figure 2.

A. Dither/Vertical Stripe Detection Module

In the preferred embodiment, dither/vertical stripe detection module 3c is a software routine. However, one of ordinary skill in the art would understand that the present invention could be practiced using a hardware circuit to carry out the logic functions described herein.

To detect a dither and/or vertical stripe pattern in an image stored in buffer 3b, the dither/vertical stripe detection module 3c examines each tile stored in buffer 3b. Dither/vertical stripe detection module 3c examines each row of the tile for a dither pattern or vertical stripe pattern. In most instances, the vertical stripe pattern is 2 pixels wide and rarely encountered.

Figures 3 and 4 illustrate dither and vertical stripe patterns, respectively. In Figures 3 and 4, the "A"s represent a first color found in a color palette for a first set of pixels in tile 5a and 5b. The B's represent a second color found in the color palette for a second set of pixels in tile 5a and 5b. If color A is red and color B is white, then the CD+G disc designer intended tile 5a in Figure 3 to be pink.

The present invention could be practiced using a gray scale palette rather than a color palette.

It should also be understood that a tile does not have to contain a complete dither pattern or vertical stripe in order for dither/vertical

stripe detection module 3c to determine whether a dither or vertical stripe is present in a tile. For example, a CD + G designer may intend to present a pink balloon image on NTSC video display 5. The interior tiles of the image would contain a dither pattern representing pink, but the tiles on the edge of the balloon would contain a partial dither pattern. The remainder of the tiles on the edge of the balloon image may contain other dither patterns or solid colors.

According to the present invention, the following steps, along with the logic flow chart shown in Figure 5, illustrate the logic of dither/vertical stripe detection module 3c.

Each tile is examined by logic block 100. As described above and as seen in Figure 3, each tile has six respective pixel color values per row in the preferred embodiment:

- 1) The center two pixel color values in a row are examined and compared by logic block 101; for example, pixel color values 20 and 21 in Figure 3 are examined and compared.
- 2) If the center two pixel color values are the same, no dither exists on this row and go to next row, as illustrated by logic block 107.
- 3) If the center two pixel color values are not the same, examine and compare adjacent left pixel color values to the center two pixel color values in logic block 103; for example, compare pixel color values 18 to 20, 19 to 21, 20 to 25, and 21 to 26 in Figure 3.
- 4) If the pixel color values compared in block 103 are equal, mark the tile as requiring dither elimination, as illustrated by logic block 106, and go to the next two rows, as illustrated by logic block 102.

- 5) If any of the pixel color value comparisons in logic block 103 are not equal, examine and compare adjacent right color values to the right pixel color values in logic block 105; for example, compare pixel color values 20 and 22, 21 and 23, 20 and 27, and 21 and 28 in Figure 3.
- 6) If the pixel color values compared in logic block 105 are equal, mark the tile as requiring dither elimination, as illustrated by logic block 106.
- 7) Go to the next two rows, as illustrated by logic block 102, and begin examining and comparing the next two rows in logic block 101.

While the present invention detects the vast majority of dither and/or vertical stripe patterns in an image, there may be certain instances where the border of a dither and/or vertical stripe may not be detected.

The vertical stripe detection logic is similar to the dither detection logic discussed above. In Figure 4, pixel color value 30 is compared to pixel color value 32 and pixel color value 31 is compared to pixel color value 33. If pixel color value 31 is equal to pixel color value 33 and pixel color value 30 is equal to pixel color value 32, but pixel color values 30 and 31 are different, the tile is marked as requiring vertical stripe elimination.

The present apparatus and method describes examining and comparing pixel color values which are accessed directly from memory. Other embodiments may include an index apparatus and/or method where pixel color values A and B in Figures 3 and 4 represent indexes or pointers to the actual color information stored elsewhere in the system. This index encoding allows for reducing the necessary memory used in the apparatus. These color values, or color pallet, are

stored at a memory location which is addressed by values A and B in Figures 3 and 4. Thus, pixel color values could easily be replaced by only changing the pixel color values at this memory location, rather than changing each pixel color value shown in Figures 3 and 4.

5

B. Dither/Vertical Stripe Modification Module

To eliminate the crosstalk conditions created by a dither pattern and/or a vertical stripe pattern in a visually pleasing way, the present invention takes into account the CD+G disc designer's purpose in creating the dither pattern and/or vertical stripe pattern. The pixel color values A and B, as shown in Figures 3 and 4, are each replaced with a new pixel color value X. X is the average of pixel color value A and pixel color value B. Thus, a video display system having a limited number of available colors or a relatively small color palette, such as the CD+G disc described above, is able to substantially increase the amount of colors displayed in an image on an NTSC video display. Since we assume that the CD+G disc designer intended pink to be displayed in an image by creating a dither pattern containing red and white pixel values, this averaging method creates a solid pink throughout the intended dithered area in a tile of the image. Since there is no longer a dither pattern and/or vertical stripe in a tile, the luma/chroma crosstalk condition is eliminated.

10

15

20

Thus, according to the present invention, the following steps illustrate the logic of dither/vertical stripe modification module 3d.

25

For each tile marked as needing dither and/or vertical stripe modification and/or for each pair of pixel color values A_i, B_j that resulted in a dither and/or vertical stripe detection condition:

- 1) Locate each color pixel value pair A_i, B_j in a tile marked as having a dither and/or vertical stripe pattern;

- 2) Average each color pixel value pair A_i, B_j to obtain an averaged value X_k (the average of this pair);
- 3) Replace each color pixel value pair A_i, B_j with X_k .

5 It may be more efficient to do the averaging (step 2 above) and replacing (step 3 above) steps at the same time as implementing the dither/vertical stripe detection module 3c, as long as both steps are completed prior to generating NTSC video signal on data path 4 to NTSC display 5.

10 The foregoing description of the preferred embodiments of the present invention has been provided for the purposes of illustration and description. It is not intended to be exhaustive or to limit the invention to the precise forms disclosed. Obviously, many modifications and variations will be apparent to practitioners skilled in the art. The embodiments were chosen and described in order to best explain the principles of the invention and its practical applications, thereby
15 enabling others skilled in the art to understand the invention for various embodiments and with the various modifications as are suited to the particular use contemplated. It is intended that the scope of the invention be defined by the following claims and their equivalents.

CLAIMS

What is claimed is:

1) A method for detecting a dither pattern in an image, comprising the steps of:

examining a first center two pixel values in a first row of a section of the image; and,

comparing the first center two pixel values to adjacent pixel values in order to determine whether the dither pattern is in the image.

2) The method of claim 1, wherein the image is to be displayed and section of the image is a tile.

3) The method of claim 2, wherein the tile comprises about a 6 pixel row by about an 12 pixel column matrix.

4) The method of claim 1, wherein the first center two pixel values include a first color value and a second color value, and the adjacent pixel values include the first color value and the second color value.

5) The method of claim 1, wherein the pixel values are retrieved from a CD + G disc.

6) The method of claim 1, wherein the pixel values are used in a National Television System Committee signal.

7) The method of claim 1, wherein the pixel values are selected from a relatively small group of color values.

8) A method for detecting a vertical stripe pattern in an image, comprising the steps of:

examining a first center two pixel values in a first row of a section of the image; and,

comparing the first center two pixel values to a second center two pixel values in a second row in order to determine whether the vertical stripe pattern is in the image.

9) The method of claim 8, wherein the section of the image is to be displayed and the section of the image is a tile.

10) A method for eliminating a dither pattern, comprising the steps of:

storing an image containing a dither pattern, including a first pixel value and a second pixel value, in a memory location;

comparing the first center two pixel values to adjacent pixel values in order to determine whether a dither pattern is in the image;

averaging the first pixel value and the second pixel value to obtain an average value; and,

substituting the first pixel value and the second pixel value stored in the memory location with the averaged value.

11) The method of claim 10, wherein the image includes a tile comprising about a 6 pixel row by about an 12 pixel column matrix.

12) The method of claim 10, wherein the first center two pixel values include a first color value and a second color value and the adjacent pixel color values include the first color value and the second color value.

13) The method of claim 10, wherein the pixel values stored in the memory location are from a CD + G disc.

14) The method of claim 10, wherein the pixel values in the memory location are used in a National Television System Committee signal.

15) The method of claim 10, wherein the pixel values are selected from a relatively small group of colors.

16) An apparatus for detecting a dither/vertical pixel pattern in an image, comprising:

a source of pixel values for an image;

means, coupled to the source, for examining a first center two pixel values in a first row of a section of the image;

means, coupled to the source, for examining adjacent pixel values in a section of the image; and

means for comparing the first center two pixel values to the adjacent pixel values in order to determine whether the dither/vertical stripe pattern is in the image.

17) The apparatus of claim 16, wherein the image is to be displayed and the section of the image is a tile.

18) The apparatus of claim 17, wherein the tile comprises about a 6 pixel row by about an 12 pixel column matrix.

19) The apparatus of claim 16, wherein the first center two pixel values include a first color value and a second color value and the adjacent pixel values include the first color value and the second color value.

20) The apparatus of claim 16, wherein the source of pixel values is generated from a CD+G disc.

21) The apparatus of claim 16, wherein the pixel values are used in a National Television System Committee color carrier frequency signal at about 3.5 Mhz.

22) The apparatus of claim 16, wherein the pixel values are selected from about a 16 color palette.

23) The apparatus of claim 16, wherein the means for examining include a software routine.

24) The apparatus of claim 16, wherein the means for comparing include a software routine.

25) An apparatus for eliminating luma/chroma crosstalk in an image to be displayed on a National Television System Committee television screen, comprising:

a memory for storing pixel color values of a section of an image;

means, coupled to the memory, for examining 1) a first center two pixel color values, including a first color value and a second color value, respectively, in a first row of the section of the image and 2) adjacent pixel color values in a section of the image;

means, coupled to the memory, for comparing the first center two pixel color values to the adjacent pixel color values in order to determine whether a dither/vertical stripe pattern is in the image; and,

means, coupled to the memory, for modifying the first color value and the second color value stored in the memory with a averaged color value of the first color value and the second color value.

26) The apparatus of claim 25, wherein the section of the image is a tile.

27) The apparatus of claim 26, wherein the tile comprises about a 6 pixel row by about an 12 pixel column matrix.

28) The apparatus of claim 25, wherein the first center two pixel color values include a first color value and a second color value and the adjacent pixel color values include the first color value and the second color value.

29) The apparatus of claim 25, wherein the pixel color values stored in the memory are from a CD + G disc.

30) The apparatus of claim 25, wherein the pixel color values are used in a National Television System Committee color carrier frequency signal at about 3.5 Mhz.

31) The apparatus of claim 25, wherein the pixel color values are selected from about a 16 color palette.

32) The apparatus of claim 25, wherein the means for examining include a software routine.

33) The apparatus of claim 25, wherein the means for modifying include a software routine.

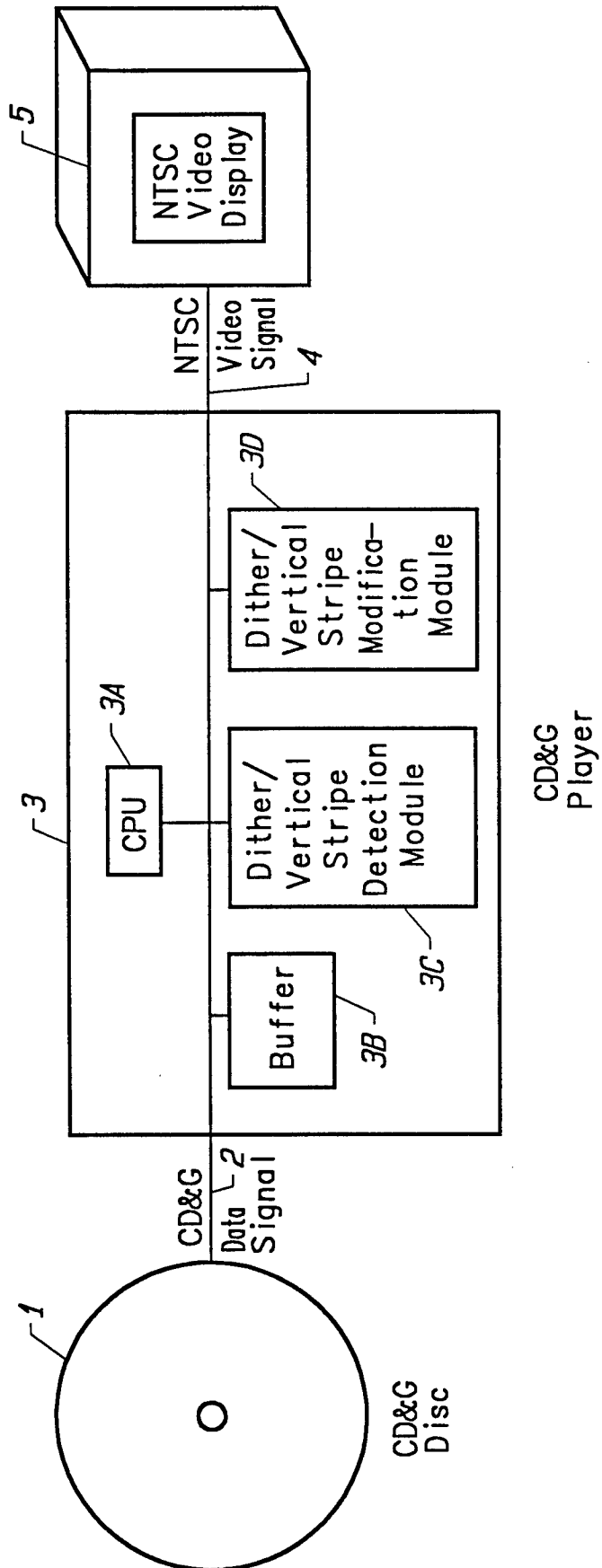

FIG. 1

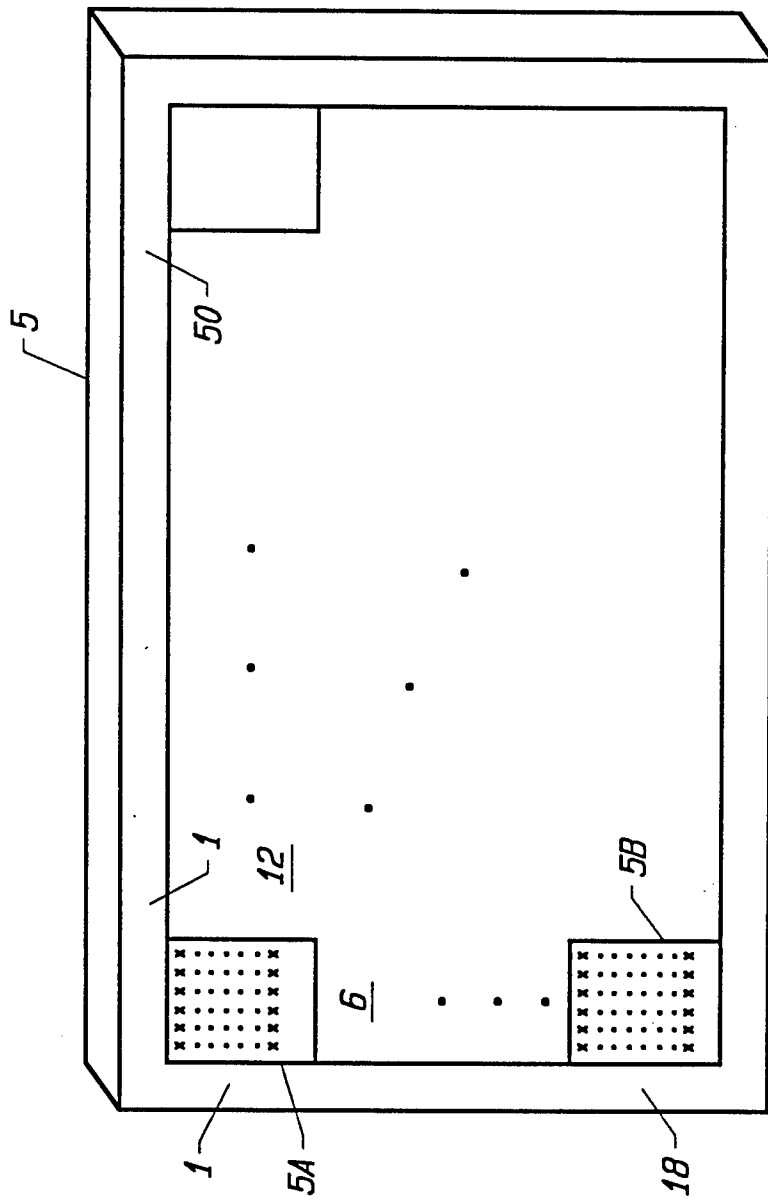

FIG. 2

Dither Pattern

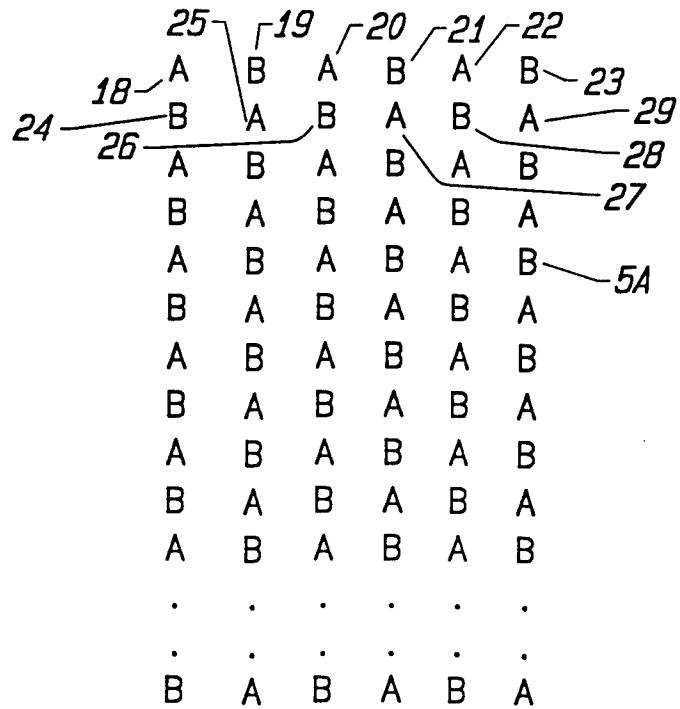

FIG. 3

Vertical Stripe Pattern

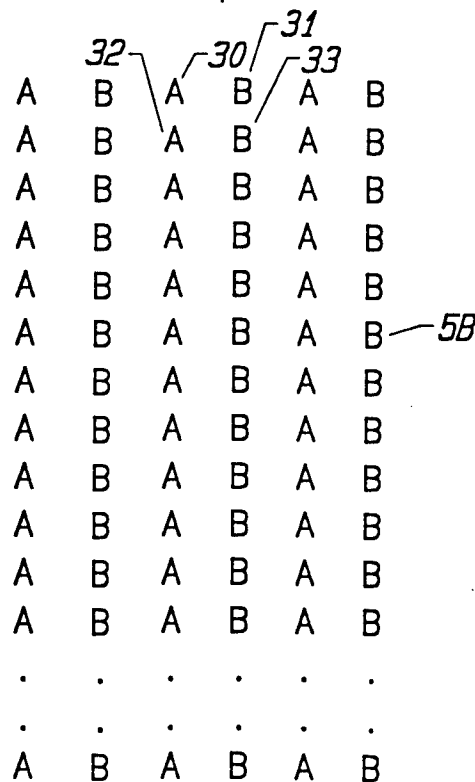
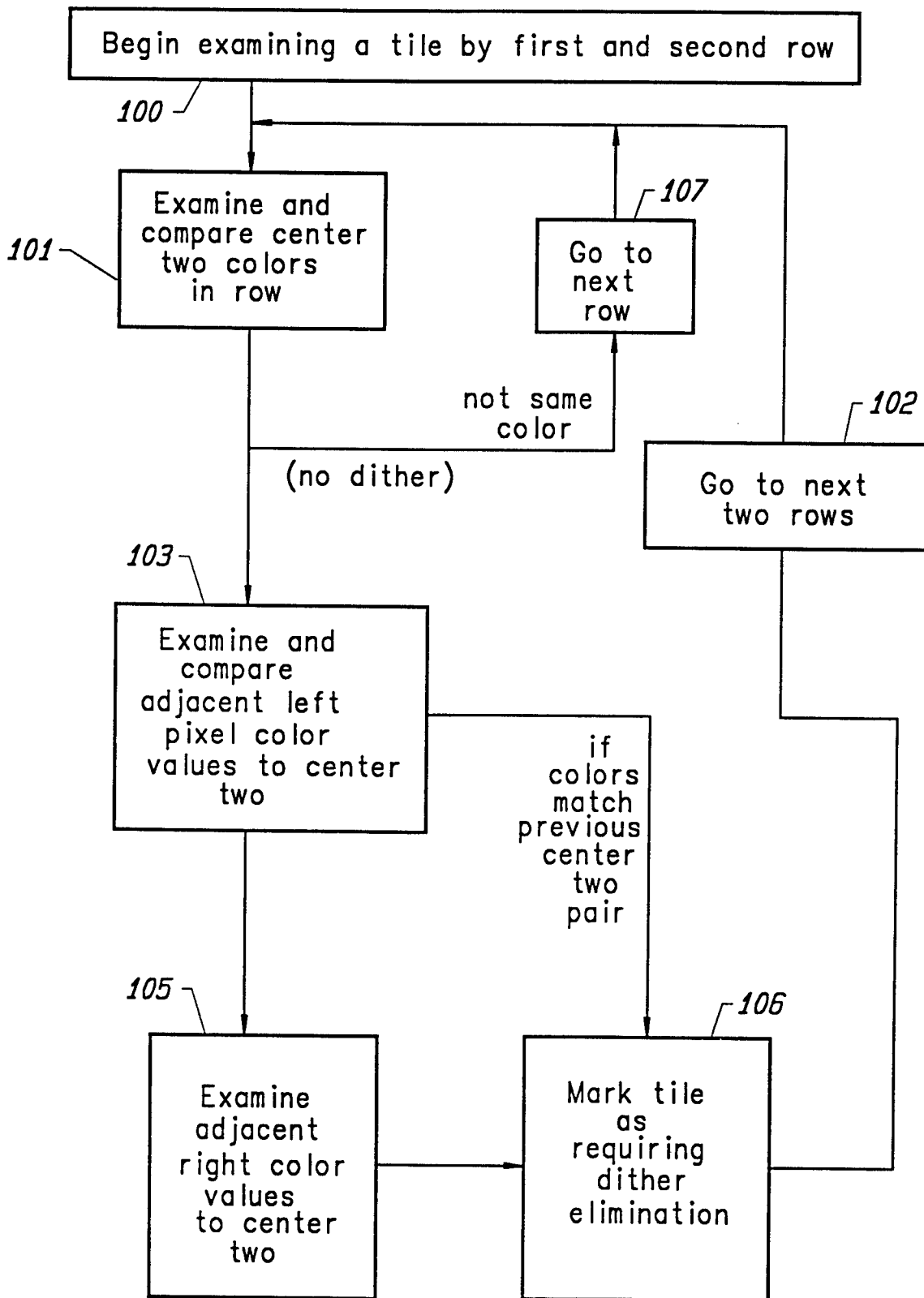

FIG. 4



Dither Detection
Logic Flow Chart

FIG. 5

INTERNATIONAL SEARCH REPORT

International application No.
PCT/US96/06430

A. CLASSIFICATION OF SUBJECT MATTER

IPC(6) :G06K 9/00

US CL :382/167, 205; 395/131

According to International Patent Classification (IPC) or to both national classification and IPC

B. FIELDS SEARCHED

Minimum documentation searched (classification system followed by classification symbols)

U.S. : 382/165, 167, 190, 205; 395/131, 135; 345/138, 153

Documentation searched other than minimum documentation to the extent that such documents are included in the fields searched

Electronic data base consulted during the international search (name of data base and, where practicable, search terms used)

C. DOCUMENTS CONSIDERED TO BE RELEVANT

Category*	Citation of document, with indication, where appropriate, of the relevant passages	Relevant to claim No.
Y	US, A, 4,630,307 (COK) 16 December 1986, Abstract, Figs. 1-5, 7a-8c, 10-14, col. 1, line 29 to col. 2, line 68, col. 4, line 12 to col. 6, line 20.	1-33
Y	US, A, 4,969,202 (GROEZINGER) 06 November 1990, Abstract, Figs. 2-3a, col. 1, line 50 to col. 2, line 22, col. 2, line 50 to col. 3, line 25.	1-33
Y	US, A, 5,249,242 (HANSON ET AL.) 28 September 1993, Abstract, Figs. 4, 11-12c, 14a-e, 19, col. 6, line 31 to col. 11, line 41.	10, 25-33

Further documents are listed in the continuation of Box C. See patent family annex.

* Special categories of cited documents:	"T" later document published after the international filing date or priority date and not in conflict with the application but cited to understand the principle or theory underlying the invention
"A" document defining the general state of the art which is not considered to be part of particular relevance	"X" document of particular relevance; the claimed invention cannot be considered novel or cannot be considered to involve an inventive step when the document is taken alone
"E" earlier document published on or after the international filing date	"Y" document of particular relevance; the claimed invention cannot be considered to involve an inventive step when the document is combined with one or more other such documents, such combination being obvious to a person skilled in the art
"L" document which may throw doubts on priority claim(s) or which is cited to establish the publication date of another citation or other special reason (as specified)	"&" document member of the same patent family
"O" document referring to an oral disclosure, use, exhibition or other means	
"P" document published prior to the international filing date but later than the priority date claimed	

Date of the actual completion of the international search

19 AUGUST 1996

Date of mailing of the international search report

30.08.96

Name and mailing address of the ISA/US
Commissioner of Patents and Trademarks
Box PCT
Washington, D.C. 20231

Facsimile No. (703) 305-3230

Authorized officer

JOSEPH MANCUSO *Joseph Mancuso*

Telephone No. (703) 305-8576