



MX23C8000

8M-BIT [1M x 8] CMOS MASK ROM

FEATURES

- 1M x 8 organization
- Single +5V power supply
- Fast access time : 100/120/150/200ns
- Totally static operation
- Completely TTL compatible
- Operating current : 25mA

- Standby current : 15uA
- Package
 - 32 pin plastic DIP
 - 32 pin plastic SOP
 - 32 pin plastic PLCC
 - 32 pin plastic TSOP

GENERAL DESCRIPTION

The MX23C8000 is a 5V only, 8M-bit, Read Only Memory. It is organized as 1M words by 8 bits, operates from a single +5V supply, has a static standby mode, and has an access time of 100/120/150/200ns. It is designed to be compatible with all microprocessors and similar applications in which high performance, large bit storage and simple interfacing are important design considerations.

MX23C8000 offers automatic power-down, with power-down controlled by the chip enable (CE) input. When CE goes high, the device automatically powers down and remains in a low-power standby modes as long as CE remains high.

PIN CONFIGURATION

32 PDIP

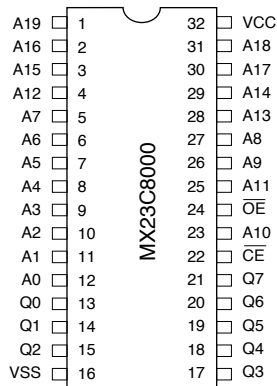

32 SOP

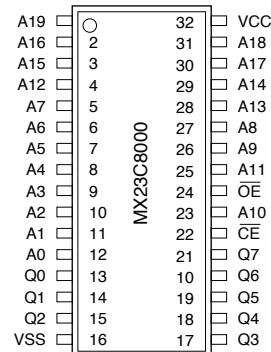

32 PLCC

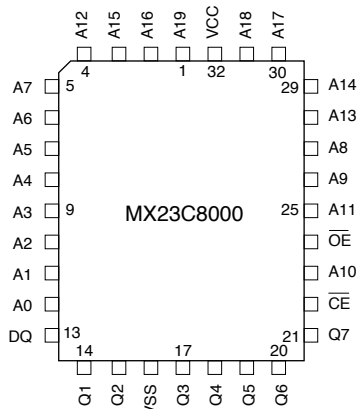

32 TSOP

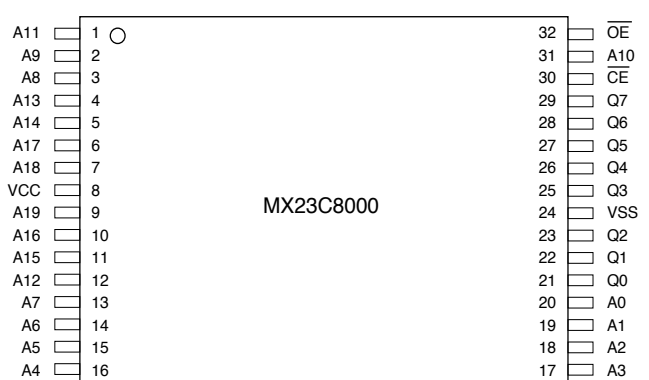

PIN DESCRIPTION

Symbol	Pin Function
A0~A19	Address Inputs
Q0~Q7	Data Outputs
\overline{CE}	Chip Enable Input
\overline{OE}	Output Enable Input
VCC	Power Supply Pin (+5V)
VSS	Ground Pin

BLOCK DIAGRAM

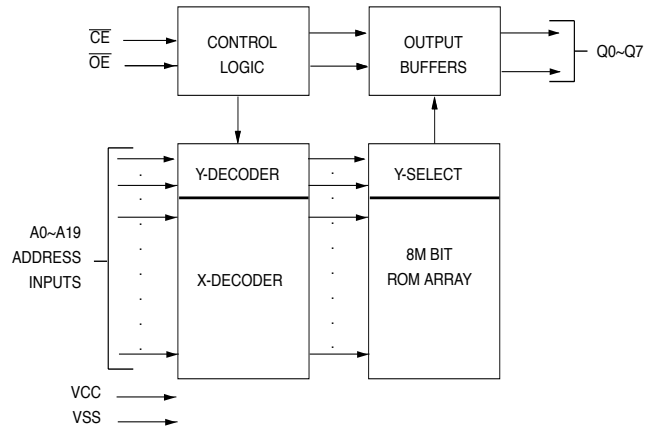

ABSOLUTE MAXIMUM RATINGS

RATING	VALUE
Ambient Operating Temperature	0° C to 70° C
Storage Temperature	-65° C to 125° C
Applied Input Voltage	-0.5V to VCC+0.5
Applied Output Voltage	-0.5V to VCC+0.5
VCC to Ground Potential	-0.5V to 7.0V
Power Dissipation	1.0W

Note: minimum DC voltage on input or I/O pins is -0.5V. During voltage transitions, inputs may undershoot VSS to -2.0V for periods of up to 20ns. Maximum DC voltage on input or I/O pins is VCC+0.5V. During voltage transitions, input may overshoot VCC to VCC+2.0V for periods of up to 20ns.



DC CHARACTERISTICS (Ta = 0° C ~ 70° C, VCC = 5.0V ± 10%)

Item	Symbol	MIN.	MAX.	Conditions
Output High Voltage	VOH	2.4V	-	IOH = -1.0mA
Output Low Voltage	VOL	-	0.4V	IOL = 2.1mA
Input High Voltage	VIH	2.2V	VCC+0.3V	
Input Low Voltage	VIL	-0.3V	0.8V	
Input Leakage Current	ILI	-	10uA	VIN=0 to 5.5V
Output Leakage Current	ILO	-	10uA	VOUT=0 to 5.5V
Power-Down Supply Current	ICC3	-	15uA	$\overline{CE} > VCC - 0.2V$
Standby Supply Current	ICC2	-	1.0mA	$\overline{CE} = VIH$
Operating Supply Current	ICC1	-	25mA	Note 1

CAPACITANCE (Ta = 25° C, f=1.0MHz (Note 2))

Item	Symbol	MIN.	MAX.	UNIT	Conditions
Input Capacitance	CIN	-	10	pF	VIN=0V
Output Capacitance	COUT	-	10	pF	VOUT=0V

AC CHARACTERISTICS (Ta = -10° C ~ 70° C, VCC = 5.0V ± 10%)

PARAMETER	SYMBOL	23C8000-10		23C8000-12		23C8000-15		23C8000-20		CONDITIONS
		MIN.	MAX.	MIN.	MAX.	MIN.	MAX.	MIN.	MAX.	
Cycle Time	tCYC	100ns	-	120ns	-	150ns	-	200ns	-	
Address Access Time	tAA	-	100ns	-	120ns	-	150ns	-	200ns	
Output Hold Time After Address Change	tOH	0ns	-	0ns	-	0ns	-	0ns	-	
Chip Enable Access Time	tCE	-	100ns	-	120ns	-	150ns	-	200ns	
Output Enable/Chip Select Access Time	tOE	-	50ns	-	50ns	-	50ns	-	50ns	
Output Low Z Delay	tLZ	0ns	-	0ns	-	0ns	-	0ns	-	Note 3
Output High Z Delay	tHZ	-	20ns	-	20ns	-	20ns	-	20ns	Note 4

Note:

1. Measured with device selected at f=5MHz and output unloaded.
2. This parameter is periodically sampled and is not 100% tested.
3. Output low-impedance delay (tLA) is measured from \overline{CE} going low.
4. Output high-impedance delay (tHZ) is measured from \overline{CE} going high.

AC Test Conditions

Input Pulse Levels	0.4V~2.4V
Input Rise and Fall Times	10ns
Input Timing Level	1.5V
Output Timing Level	0.8V and 2.0V
Output Load	See Figure

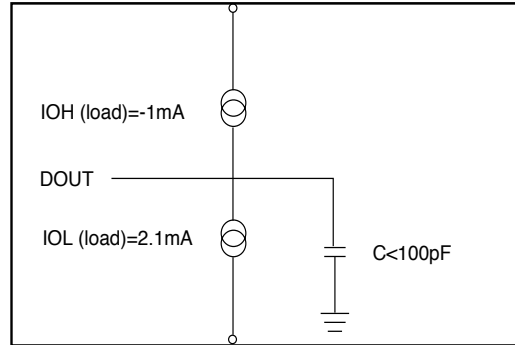

Note:

No output loading is present in tester load board.

Active loading is used and under software programming control.

Output loading capacitance includes load board's and all stray capacitance.

TIMING DIAGRAM

PROPAGATION DELAY FROM ADDRESS ($\overline{CE}/\overline{OE}$ =ACTIVE)

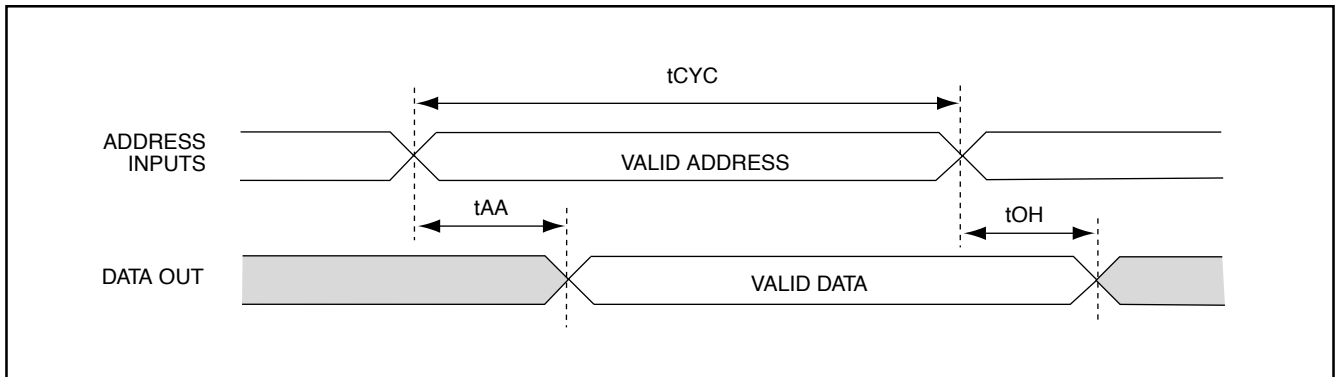

PROPAGATION DELAY FROM CHIP ENABLE (ADDRESS VALID)

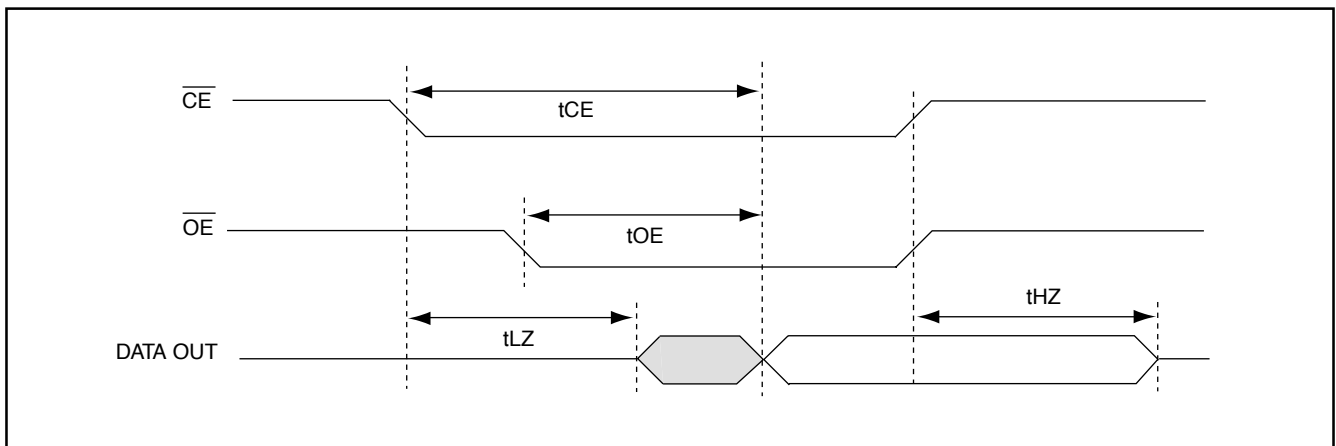



MX23C8000

ORDER INFORMATION

Part No.	Access Time	Operating Current MAX.	Standby Current MAX.	Package
MX23C8000PC-10	100ns	25mA	15uA	32 pin DIP
MX23C8000MC-10	100ns	25mA	15uA	32 pin SOP
MX23C8000QC-10	100ns	25mA	15uA	32 pin PLCC
MX23C8000TC-10	100ns	25mA	15uA	32 pin TSOP
MX23C8000PC-12	120ns	25mA	15uA	32 pin DIP
MX23C8000MC-12	120ns	25mA	15uA	32 pin SOP
MX23C8000QC-12	120ns	25mA	15uA	32 pin PLCC
MX23C8000TC-12	120ns	25mA	15uA	32 pin TSOP
MX23C8000PC-15	150ns	25mA	15uA	32 pin DIP
MX23C8000MC-15	150ns	25mA	15uA	32 pin SOP
MX23C8000QC-15	150ns	25mA	15uA	32 pin PLCC
MX23C8000TC-15	150ns	25mA	15uA	32 pin TSOP
MX23C8000PC-20	200ns	25mA	15uA	32 pin DIP
MX23C8000MC-20	200ns	25mA	15uA	32 pin SOP
MX23C8000QC-20	200ns	25mA	15uA	32 pin PLCC
MX23C8000TC-20	200ns	25mA	15uA	32 pin TSOP

PACKAGE INFORMATION

Title: Package Outline for PDIP 32L(600MIL)

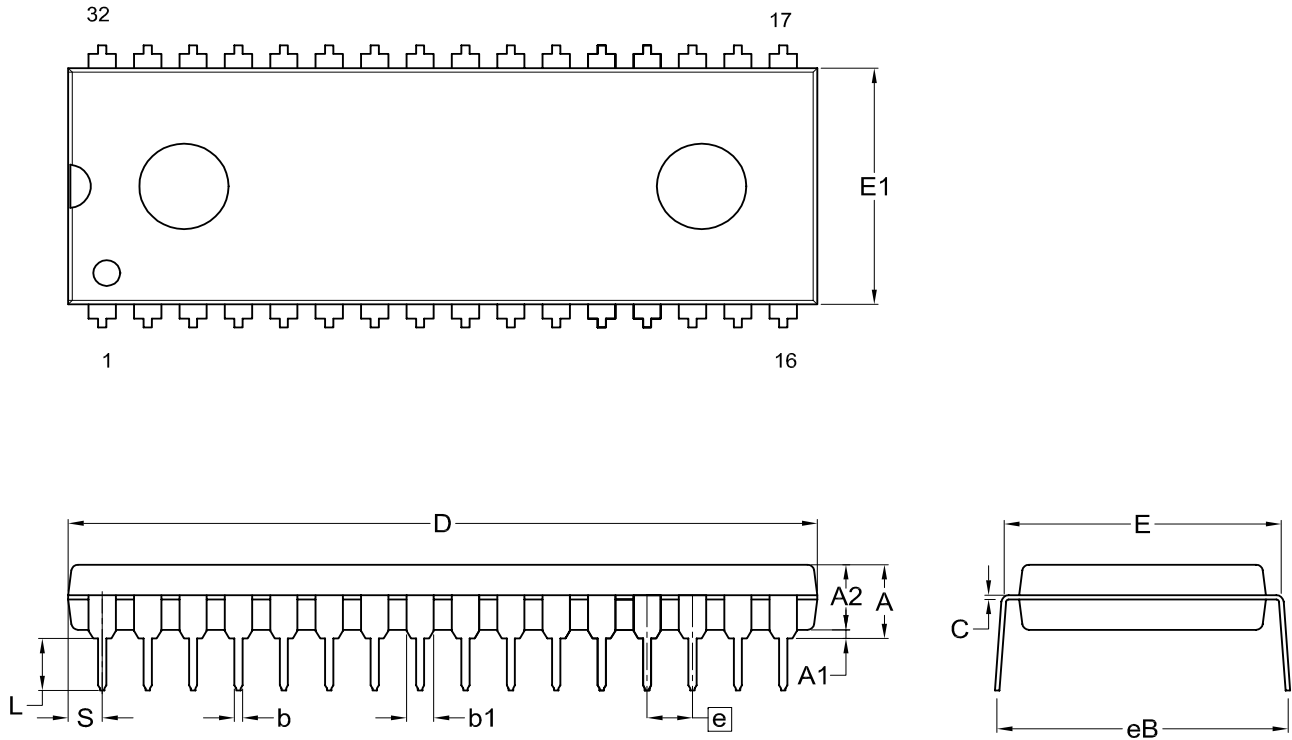

Dimensions (inch dimensions are derived from the original mm dimensions)

SYMBOL		A	A1	A2	b	b1	C	D	E	E1	e	eB	L	S
UNIT														
mm	Min.	—	0.38	3.73	0.38	1.14	0.20	41.78	15.11	13.84		15.75	2.92	1.65
	Nom.	—	—	3.94	0.46	1.27	0.25	41.91	15.24	13.97	2.54	16.51	3.30	1.90
	Max.	4.90	0.76	4.14	0.53	1.40	0.30	42.04	15.37	14.10		17.27	3.68	2.16
Inch	Min.	---	0.015	0.147	0.015	0.045	0.008	1.645	0.595	0.545		0.620	0.115	0.065
	Nom.	---	---	0.155	0.018	0.050	0.010	1.650	0.600	0.550	0.100	0.650	0.130	0.075
	Max.	0.193	0.030	0.163	0.021	0.055	0.012	1.655	0.605	0.555		0.680	0.145	0.085

DWG.NO.	REVISION	REFERENCE			ISSUE DATE
		JEDEC	EIAJ		
6110-0202.2	7				11-24-'03

Title: Package Outline for SOP 32L (450MIL)

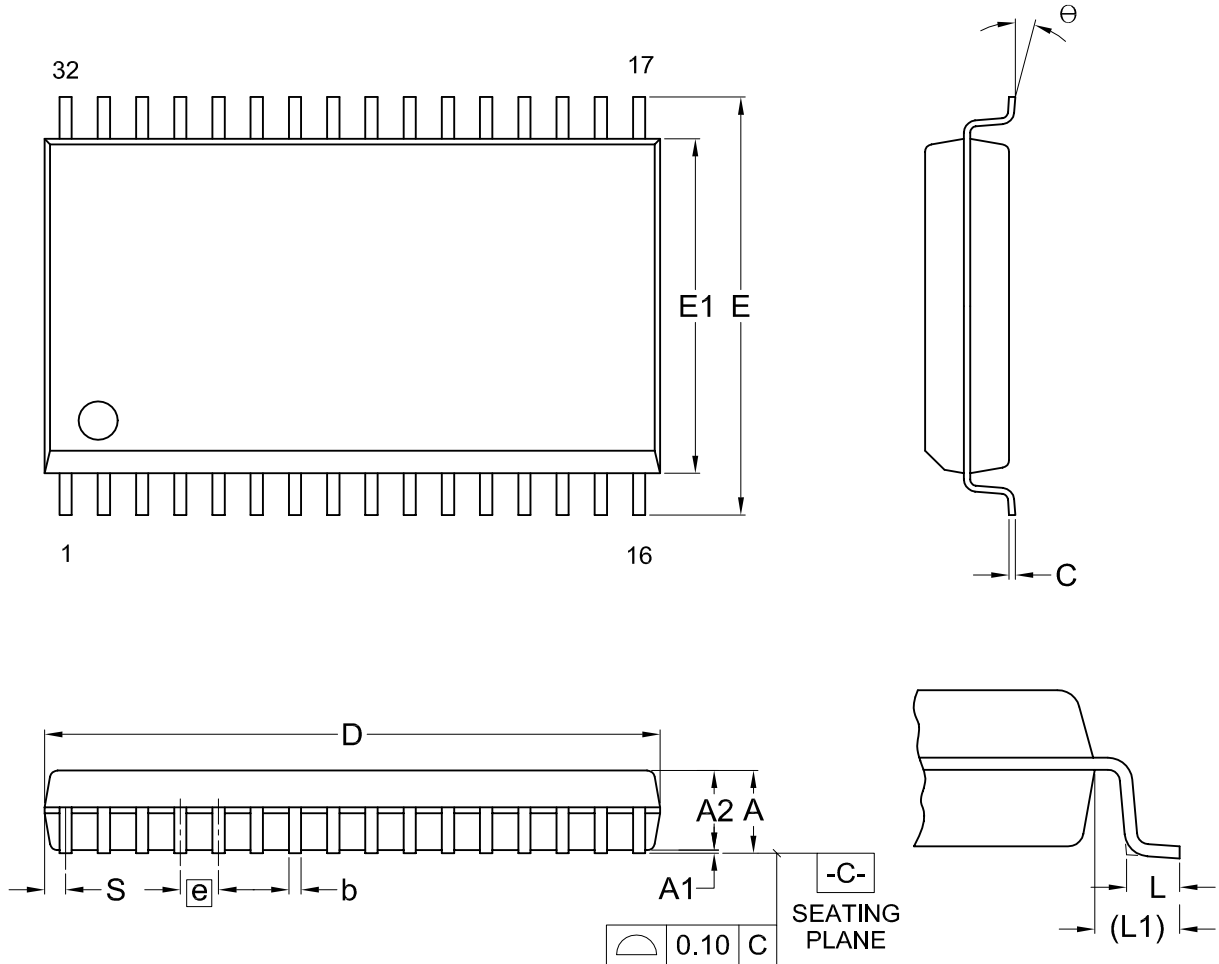

Dimensions (inch dimensions are derived from the original mm dimensions)

SYMBOL		A	A1	A2	b	C	D	E	E1	e	L	L1	S	θ
UNIT														
mm	Min.	---	0.10	2.59	0.36	0.15	20.32	13.92	11.18		0.56	1.20	0.58	0
	Nom.	---	0.15	2.69	0.41	0.20	20.45	14.12	11.30	1.27	0.76	1.40	0.70	5
	Max.	3.00	0.20	2.80	0.51	0.25	20.57	14.32	11.43		0.96	1.60	0.83	8
Inch	Min.	---	0.004	0.102	0.014	0.006	0.800	0.548	0.440		0.022	0.047	0.023	0
	Nom.	---	0.006	0.106	0.016	0.008	0.805	0.556	0.445	0.050	0.030	0.055	0.028	5
	Max.	0.118	0.008	0.110	0.020	0.010	0.810	0.564	0.450		0.038	0.063	0.033	8

DWG.NO.	REVISION	REFERENCE			ISSUE DATE
		JEDEC	EIAJ		
6110-1404	5	MO-099			11-26-'03

Title: Package Outline for 32L PLCC

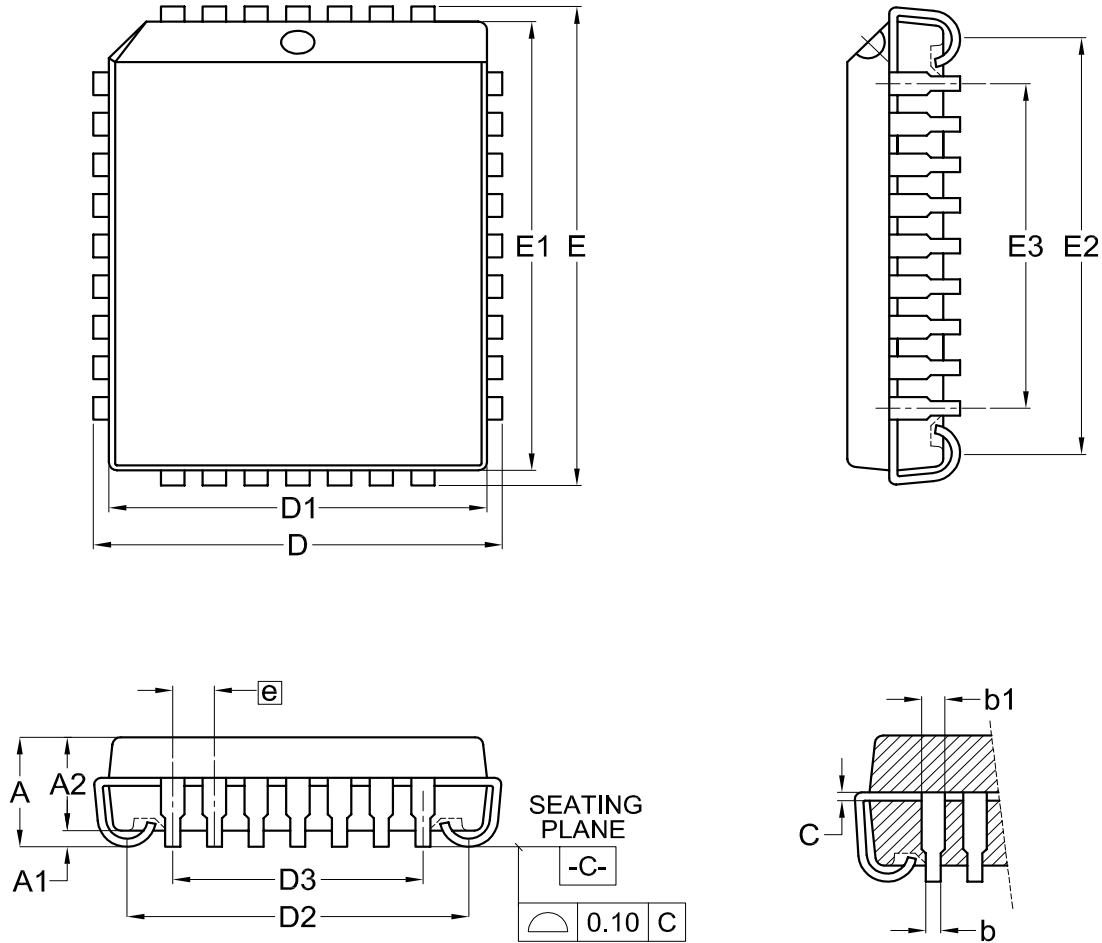

Dimensions (inch dimensions are derived from the original mm dimensions)

SYMBOL		A	A1	A2	b	b1	C	D	D1	D2	D3	E	E1	E2	E3	e
UNIT																
mm	Min.	—	0.38	2.69	0.38	0.61	0.20	12.32	11.36	10.11		14.86	13.98	12.65		
	Nom.	—	0.58	2.79	0.46	0.71	0.25	12.45	11.43	10.41	7.62	14.99	14.05	12.95	10.16	1.27
	Max.	3.55	0.81	2.89	0.54	0.81	0.30	12.58	11.50	10.71		15.12	14.12	13.25		
Inch	Min.	---	0.015	0.106	0.015	0.024	0.008	0.485	0.447	0.398		0.585	0.550	0.498		
	Nom.	---	0.023	0.110	0.018	0.028	0.010	0.490	0.450	0.410	0.300	0.590	0.553	0.510	0.400	0.050
	Max.	0.140	0.032	0.114	0.021	0.032	0.012	0.495	0.453	0.422		0.595	0.556	0.522		

DWG.NO.	REVISION	REFERENCE			ISSUE DATE
		JEDEC	EIAJ		
6110-2002	7	MS-016			12-10-'03

Title: Package Outline for TSOP(I) 32L (8X20mm)

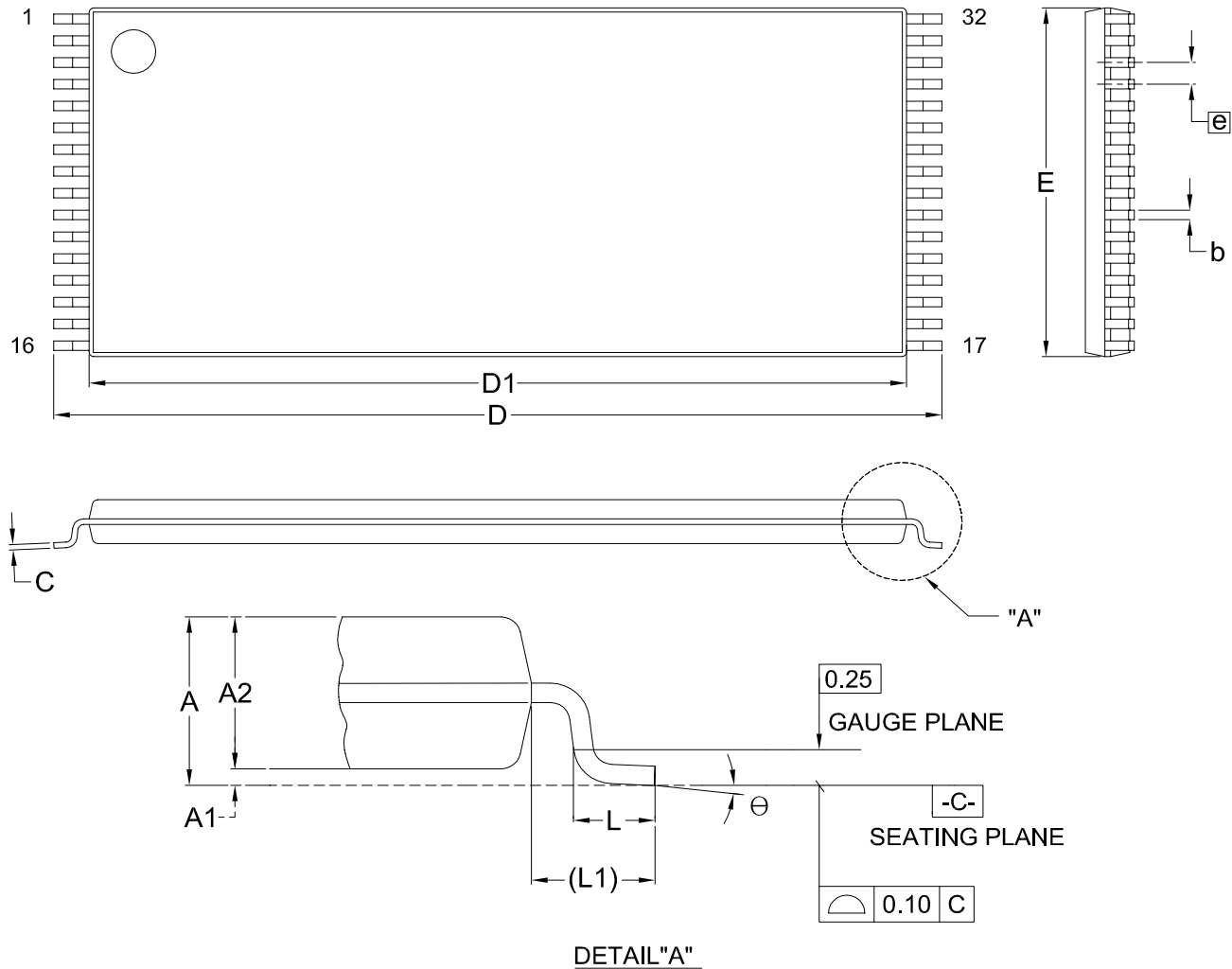

Dimensions (inch dimensions are derived from the original mm dimensions)

SYMBOL		A	A1	A2	b	C	D	D1	E	e	L	L1	Θ
mm	Min.	---	0.05	0.95	0.17	0.10	19.80	18.30	7.90		0.50	0.70	0
	Nom.	---	0.10	1.00	0.20	0.15	20.00	18.40	8.00	0.50	0.60	0.80	5
	Max.	1.20	0.15	1.05	0.27	0.21	20.20	18.50	8.10		0.70	0.90	8
Inch	Min.	---	0.002	0.037	0.007	0.004	0.780	0.720	0.311		0.020	0.028	0
	Nom.	---	0.004	0.039	0.008	0.006	0.787	0.724	0.315	0.020	0.024	0.031	5
	Max.	0.047	0.006	0.041	0.011	0.008	0.795	0.728	0.319		0.028	0.035	8

DWG.NO.	REVISION	REFERENCE			ISSUE DATE
		JEDEC	EIAJ		
6110-1604	9	MO-142			11-26-'03



REVISION HISTORY

REVISION	DESCRIPTION	PAGE	DATE
3.4	tHZ:70ns max. ---> 20ns max.		SEP/25/1997
3.5	AC CHARACTERISTICS tOH 10ns-->0ns	P3	JAN/29/1999
3.6	Modify PIN CONFIGUTATION of 32SOP 30pin A19-->A17 ; 24pin CE/ \overline{CE} -->OE/ \overline{OE}	P1	JUN/08/2000
3.7	Modify Pin Configuration--32TSOP	P1	NOV/08/2000
3.8	Modify Package Information	P5~8	JUL/16/2001
3.9	1. Modify Operating current: 40mA-->25mA 2. Modify Standby current: 100uA-->15uA 3. Modify OE/ \overline{OE} --> \overline{OE} ; CE/ \overline{CE} --> \overline{CE}	P1,2 P1,2 P1,2	APR/25/2002
4.0	1. Modify Operating current: 40mA-->25mA 2. Modify Standby current: 100uA-->15uA	P4 P4	APR/26/2002
4.1	Modify Package Information	P5~8	NOV/21/2002
4.2	1. Modify "ABSOLUTE MAXIMUM RATINGS" note	P2	JUN/18/2003
4.3	1. Modify tACE-->tCE, tAOE-->tOE 2. Modify tOE:80ns(max.)-->50ns(max.)	P3,4 P3	JUL/03/2003



MX23C8000

MACRONIX INTERNATIONAL Co., LTD.

Headquarters:

TEL:+886-3-578-6688

FAX:+886-3-563-2888

Europe Office :

TEL:+32-2-456-8020

FAX:+32-2-456-8021

Hong Kong Office :

TEL:+86-755-834-335-79

FAX:+86-755-834-380-78

Japan Office :

Kawasaki Office :

TEL:+81-44-246-9100

FAX:+81-44-246-9105

Osaka Office :

TEL:+81-6-4807-5460

FAX:+81-6-4807-5461

Singapore Office :

TEL:+65-6346-5505

FAX:+65-6348-8096

Taipei Office :

TEL:+886-2-2509-3300

FAX:+886-2-2509-2200

MACRONIX AMERICA, INC.

TEL:+1-408-262-8887

FAX:+1-408-262-8810

<http://www.macronix.com>
